

FRONT VIEW  
PRIVATE OFFICE TYPICAL

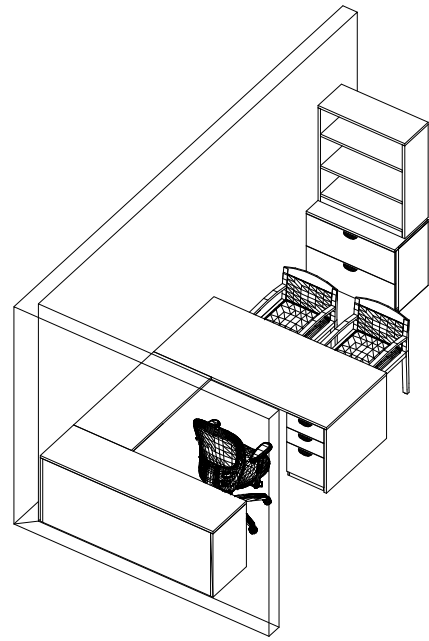

BACK VIEW

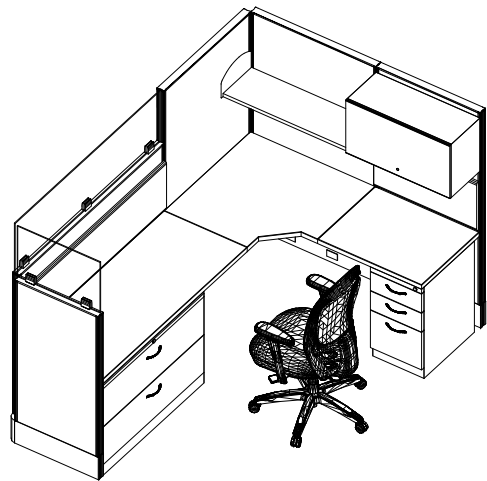

INSIDE VIEW  
STATION TYPICAL 6' X 8'

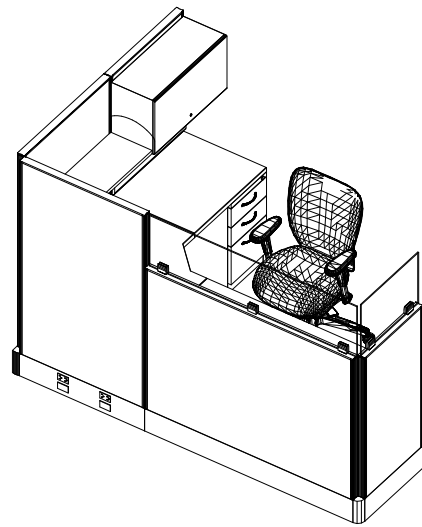

OUTSIDE VIEW

Client Name: USI	Project Name: Columbia SC 7th Fl.	Quote # : 2345FDT	Salesperson: Don Tisch
KAD Associates 498 Inman Avenue Suite 201 T: 732 943-2192 F: 732 943-2194 www.kad-associates.com	Drawing Name: Furniture Plan	Floor Name / # : -	Drawing By: DV
		RM. Name / # : -	Date: 3-19-14
			Scale: -

